

DISEÑO MECÁNICO

INSTRUMENTO POLIMA-2

PLANOS DE PARTES MECÁNICAS DISEÑADAS Y CONSTRUIDAS
EN EL TALLER DE PRECISIÓN DEL IA-UNAM

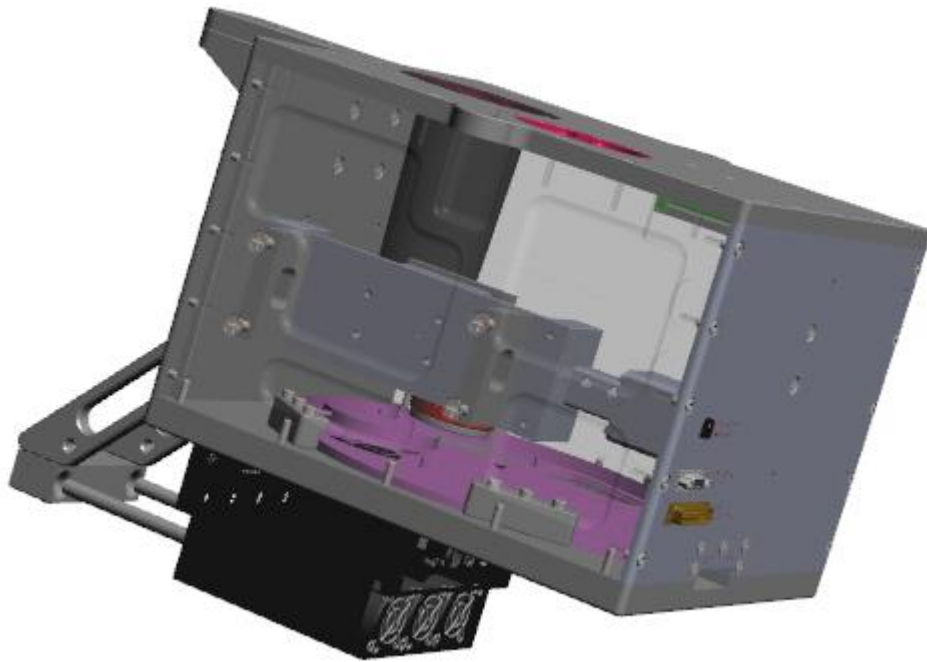

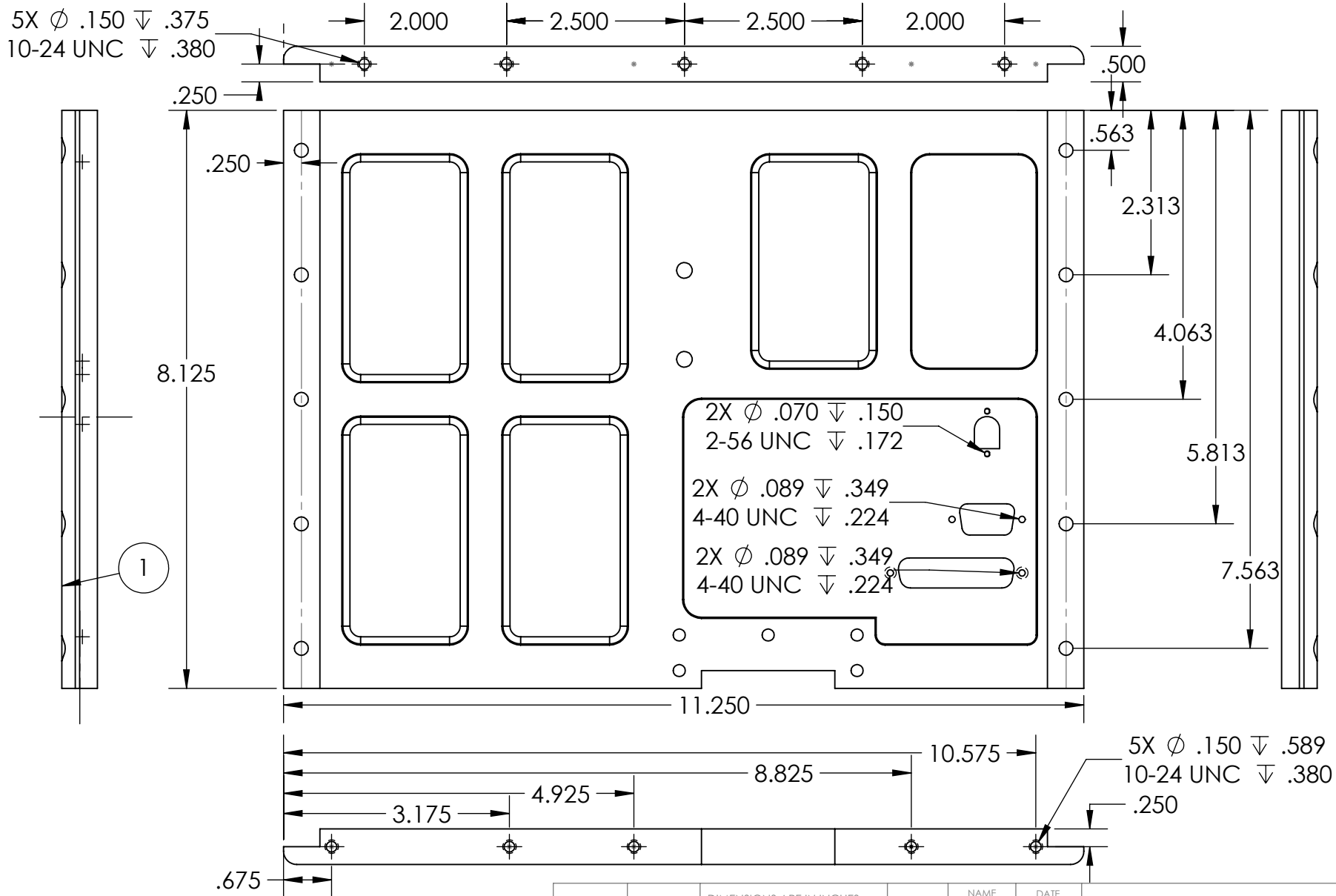

PROPRIETARY AND CONFIDENTIAL
 THE INFORMATION CONTAINED IN THIS DRAWING IS THE SOLE PROPERTY OF <INSERT COMPANY NAME HERE>. ANY REPRODUCTION IN PART OR AS A WHOLE WITHOUT THE WRITTEN PERMISSION OF <INSERT COMPANY NAME HERE> IS PROHIBITED.

		DIMENSIONS ARE IN INCHES TOLERANCES: FRACTIONAL \pm ANGULAR: MACH \pm BEND \pm TWO PLACE DECIMAL \pm THREE PLACE DECIMAL \pm		NAME J V	DATE	IAUNAM instrumentacion	
		MATERIAL --		CHECKED		SIZE A DWG. NO. REV. SCALE:1:2 WEIGHT: SHEET 1 OF 2	
		FINISH --		ENG APPR.			
NEXT ASSY USED ON				MFG APPR.			
APPLICATION		DO NOT SCALE DRAWING		Q.A.			
				COMMENTS: MACHINED PER CAD FILE			

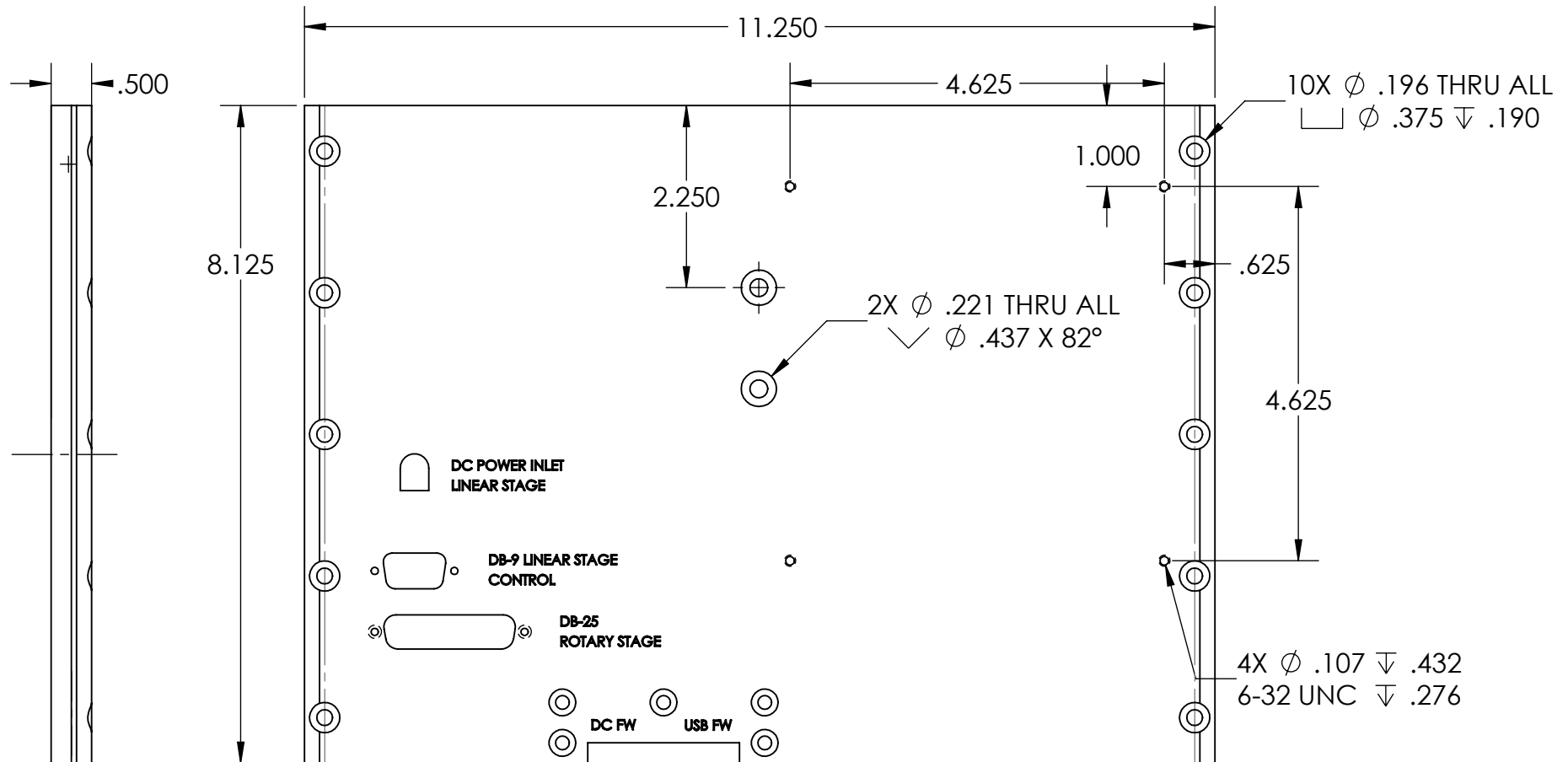

ENGRAVE PER DRAWING

PROPRIETARY AND CONFIDENTIAL
 THE INFORMATION CONTAINED IN THIS DRAWING IS THE SOLE PROPERTY OF <INSERT COMPANY NAME HERE>. ANY REPRODUCTION IN PART OR AS A WHOLE WITHOUT THE WRITTEN PERMISSION OF <INSERT COMPANY NAME HERE> IS PROHIBITED.

		UNLESS OTHERWISE SPECIFIED:		NAME	DATE
		DIMENSIONS ARE IN INCHES		DRAWN	
		TOLERANCES:		CHECKED	
		FRACTIONAL \pm		ENG APPR.	
		ANGULAR: MACH \pm BEND \pm		MFG APPR.	
		TWO PLACE DECIMAL \pm		Q.A.	
		THREE PLACE DECIMAL \pm		COMMENTS:	
		INTERPRET GEOMETRIC TOLERANCING PER:			
		MATERIAL			
		ALUMINUM 6061			
		FINISH			
		BLACK ANODIZE			
NEXT ASSY	USED ON				
APPLICATION		DO NOT SCALE DRAWING			

TITLE:		
BACK-WALL		
SIZE	DWG. NO.	REV
A		
SCALE: 1:2	WEIGHT:	SHEET 2 OF 2

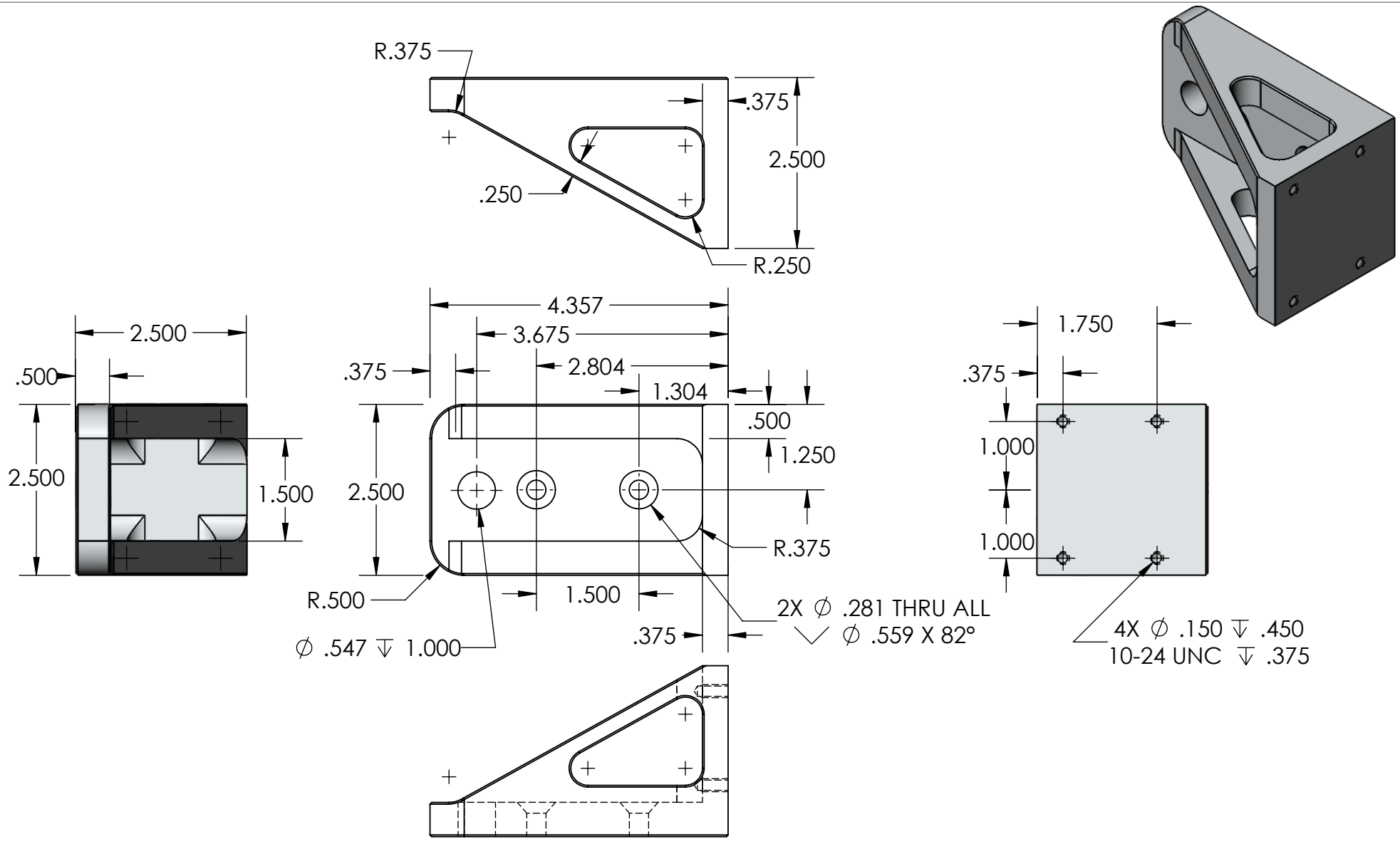

$2X \ \phi \ .281 \ \text{THRU ALL}$
 $\phi \ .559 \ \times \ 82^\circ$
 $4X \ \phi \ .150 \ \nabla \ .450$
 $10-24 \ \text{UNC} \ \nabla \ .375$

PROPRIETARY AND CONFIDENTIAL
 THE INFORMATION CONTAINED IN THIS DRAWING IS THE SOLE PROPERTY OF <INSERT COMPANY NAME HERE>. ANY REPRODUCTION IN PART OR AS A WHOLE WITHOUT THE WRITTEN PERMISSION OF <INSERT COMPANY NAME HERE> IS PROHIBITED.

		DIMENSIONS ARE IN INCHES		NAME	DATE	IAUNAM INSTRUMENTACION
		TOLERANCES:		JV		
		FRACTIONAL ±		CHECKED		BOLT-GUZET
		ANGULAR: MACH ± BEND ±		ENG APPR.		
		TWO PLACE DECIMAL ±		MFG APPR.		
		THREE PLACE DECIMAL ±		Q.A.		
		MATERIAL ALUMINIO		COMMENTS:		SIZE A DWG. NO. REV.
NEXT ASSY	USED ON	FINISH BLACK ANODIZE		MACHINED PER CAD FILE		
APPLICATION		DO NOT SCALE DRAWING				SCALE:1:2 WEIGHT: SHEET 1 OF 1

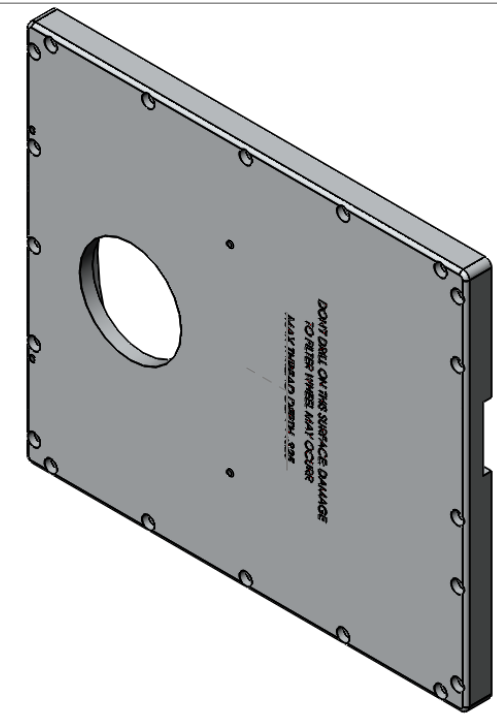
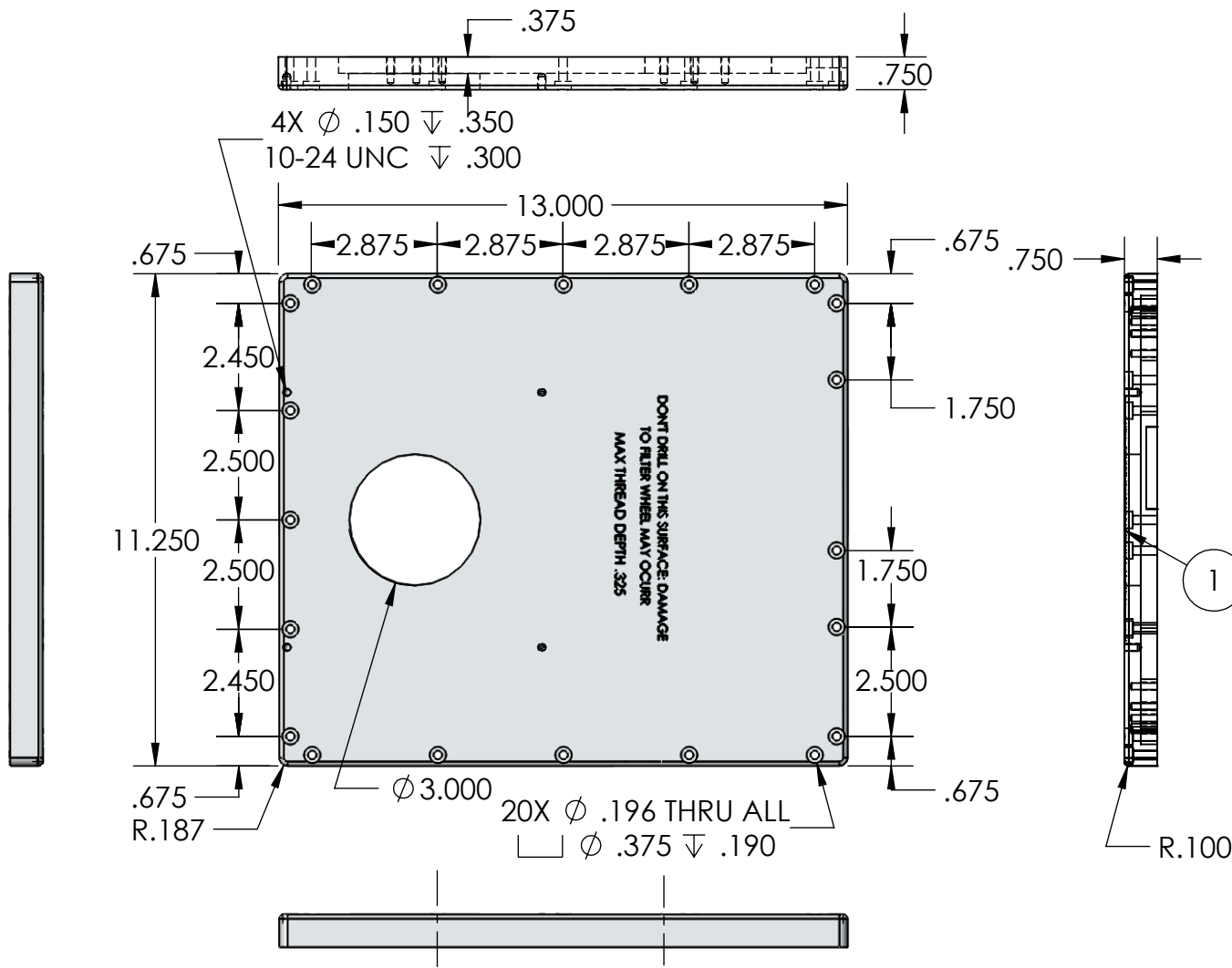

PROPRIETARY AND CONFIDENTIAL
 THE INFORMATION CONTAINED IN THIS DRAWING IS THE SOLE PROPERTY OF <INSERT COMPANY NAME HERE>. ANY REPRODUCTION IN PART OR AS A WHOLE WITHOUT THE WRITTEN PERMISSION OF <INSERT COMPANY NAME HERE> IS PROHIBITED.

		DIMENSIONS ARE IN INCHES TOLERANCES: FRACTIONAL \pm ANGULAR: MACH \pm BEND \pm TWO PLACE DECIMAL \pm THREE PLACE DECIMAL \pm		NAME J V	DATE	IAUNAM instrumentacion	
		MATERIAL ALUMINUM 6061		CHECKED		BOTTOM-PLATE	
		FINISH BLACK ANODIZE		ENG APPR.			
		APPLICATION DO NOT SCALE DRAWING		MFG APPR.			
NEXT ASSY	USED ON	COMMENTS: MACHINED PER CAD FILE		Q.A.		SIZE A	DWG. NO.
						SCALE:1:4	WEIGHT:
						SHEET 1 OF 2	

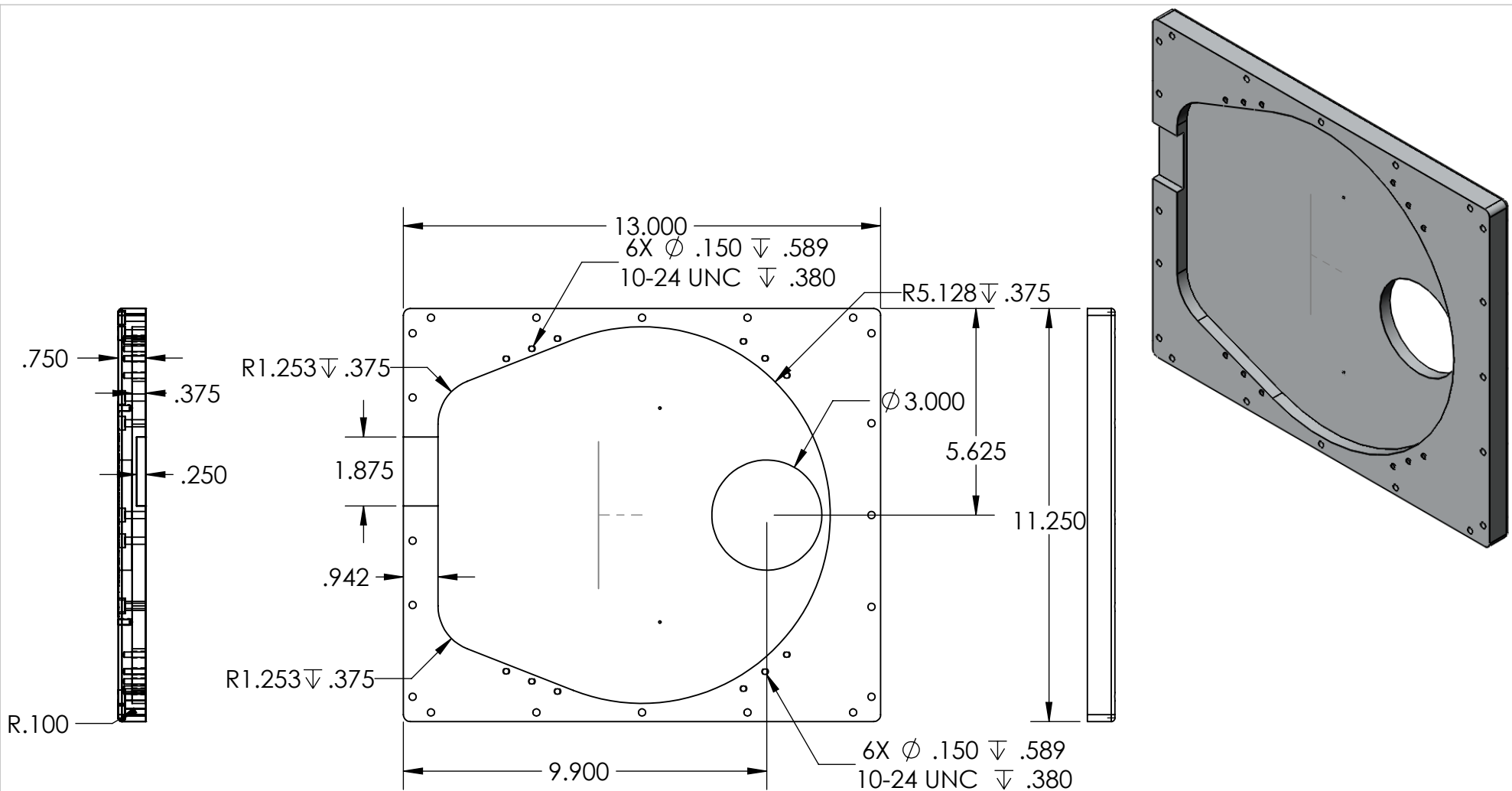

PROPRIETARY AND CONFIDENTIAL
 THE INFORMATION CONTAINED IN THIS DRAWING IS THE SOLE PROPERTY OF <INSERT COMPANY NAME HERE>. ANY REPRODUCTION IN PART OR AS A WHOLE WITHOUT THE WRITTEN PERMISSION OF <INSERT COMPANY NAME HERE> IS PROHIBITED.

		UNLESS OTHERWISE SPECIFIED:	NAME	DATE
		DIMENSIONS ARE IN INCHES	DRAWN	
		TOLERANCES:	CHECKED	
		FRACTIONAL \pm	ENG APPR.	
		ANGULAR: MACH \pm BEND \pm	MFG APPR.	
		TWO PLACE DECIMAL \pm	Q.A.	
		THREE PLACE DECIMAL \pm	COMMENTS:	
		INTERPRET GEOMETRIC TOLERANCING PER:	MACHINED PER CAD FILE	
		MATERIAL		
		ALUMINUM 6061		
		FINISH		
		BLACK ANODIZE		
NEXT ASSY	USED ON	APPLICATION	DO NOT SCALE DRAWING	

TITLE:		
BOTTOM-PLATE		
SIZE	DWG. NO.	REV
A		
SCALE: 1:4	WEIGHT:	SHEET 2 OF 2

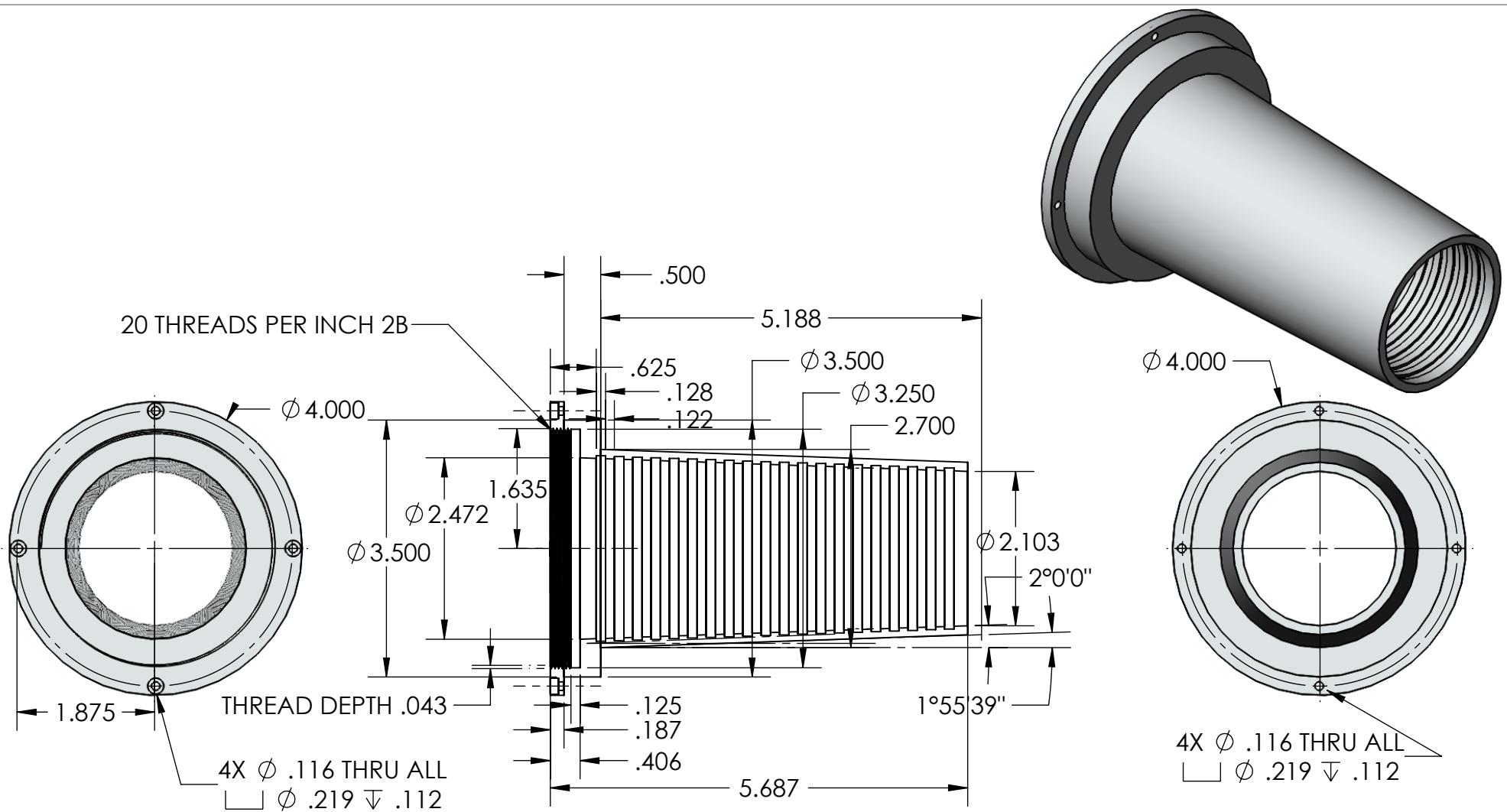

PROPRIETARY AND CONFIDENTIAL
 THE INFORMATION CONTAINED IN THIS DRAWING IS THE SOLE PROPERTY OF <INSERT COMPANY NAME HERE>. ANY REPRODUCTION IN PART OR AS A WHOLE WITHOUT THE WRITTEN PERMISSION OF <INSERT COMPANY NAME HERE> IS PROHIBITED.

		DIMENSIONS ARE IN INCHES TOLERANCES: FRACTIONAL ± ANGULAR: MACH ± BEND ± TWO PLACE DECIMAL ± THREE PLACE DECIMAL ±		NAME J V	DATE	IAUNAM instrumentacion	
		MATERIAL ALUMINUM 6061		DRAWN		BUFFLE-LIGHT-TRAP	
		FINISH BLACK ANODIZE		CHECKED			
NEXT ASSY		USED ON		ENG APPR.			
APPLICATION		DO NOT SCALE DRAWING		MFG APPR.			
				Q.A.		COMMENTS: MACHINED PER CAD FILE	
				SIZE A	DWG. NO.	REV.	
				SCALE:1:2	WEIGHT:	SHEET 1 OF 1	

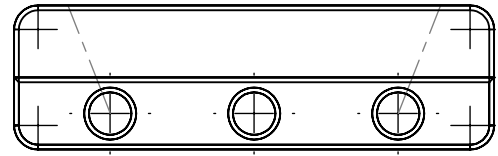
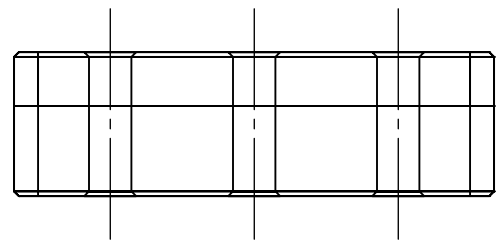
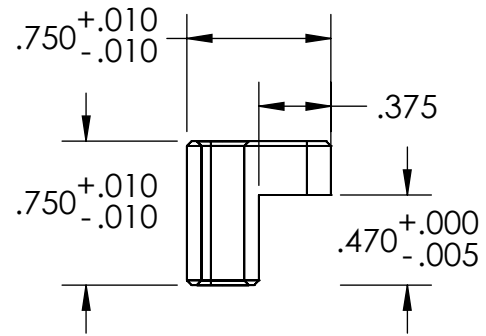
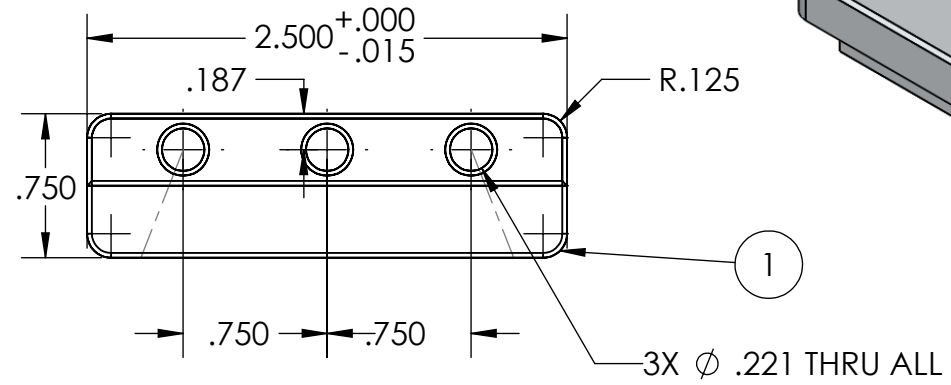
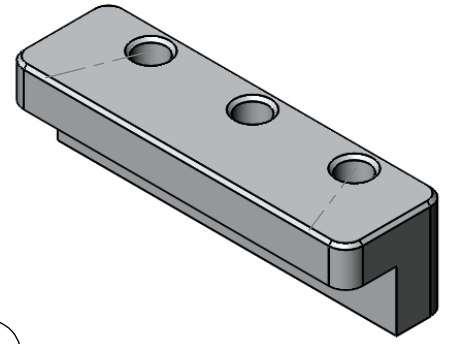

PROPRIETARY AND CONFIDENTIAL
 THE INFORMATION CONTAINED IN THIS DRAWING IS THE SOLE PROPERTY OF <INSERT COMPANY NAME HERE>. ANY REPRODUCTION IN PART OR AS A WHOLE WITHOUT THE WRITTEN PERMISSION OF <INSERT COMPANY NAME HERE> IS PROHIBITED.

		DIMENSIONS ARE IN INCHES TOLERANCES: FRACTIONAL ± ANGULAR: MACH ± BEND ± TWO PLACE DECIMAL ± THREE PLACE DECIMAL ±		NAME JV	DATE	IAUNAM instrumentacion	
		MATERIAL ALUMINUM		CHECKED		FILTER-WHEEL-CLAMP	
		FINISH BLACK ANODIZE		ENG APPR.			
NEXT ASSY	USED ON			MFG APPR.		REV.	
APPLICATION		DO NOT SCALE DRAWING		COMMENTS: MACHINED PER CAD FILE		SIZE A	DWG. NO.
						SCALE:1:1	WEIGHT:
						SHEET 1 OF 1	

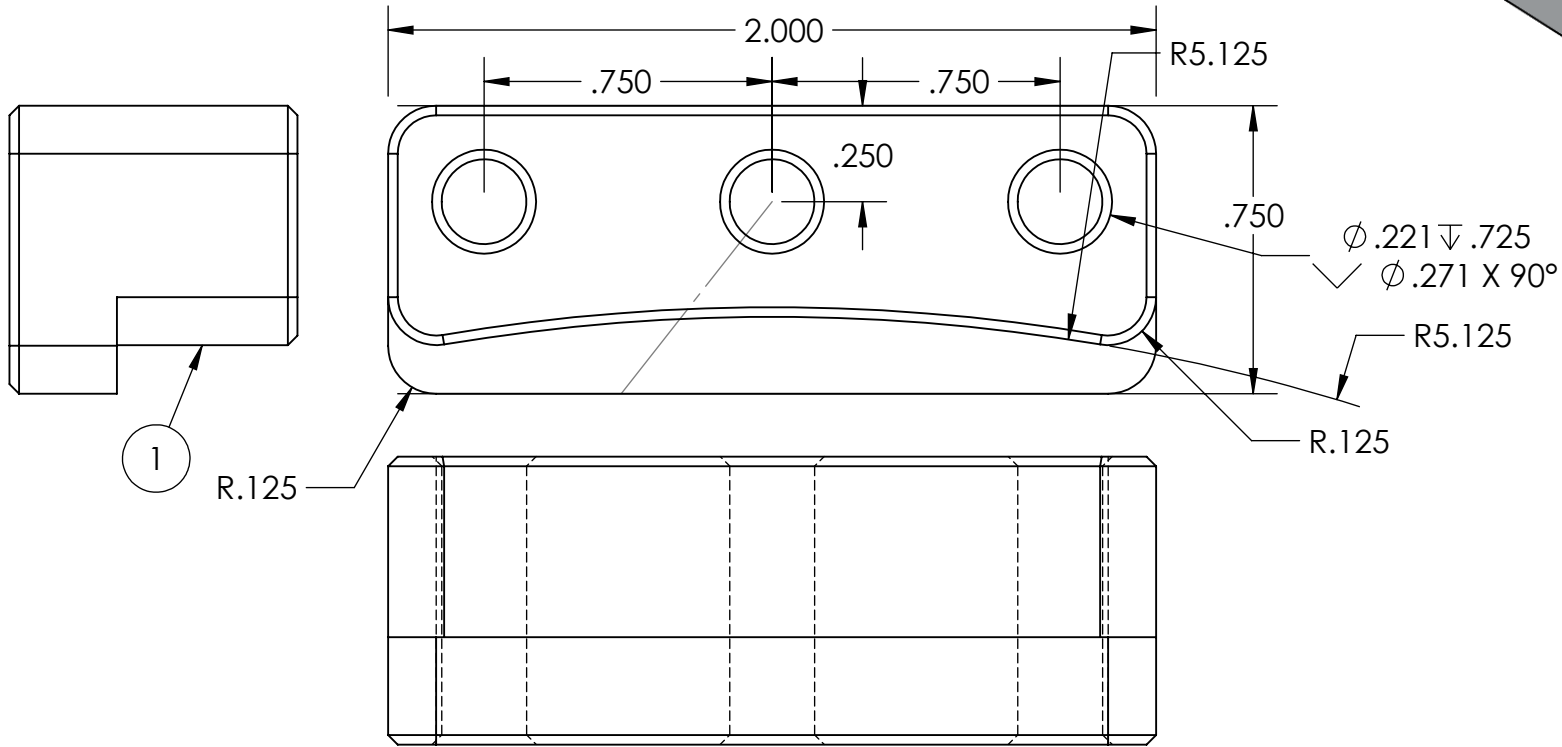
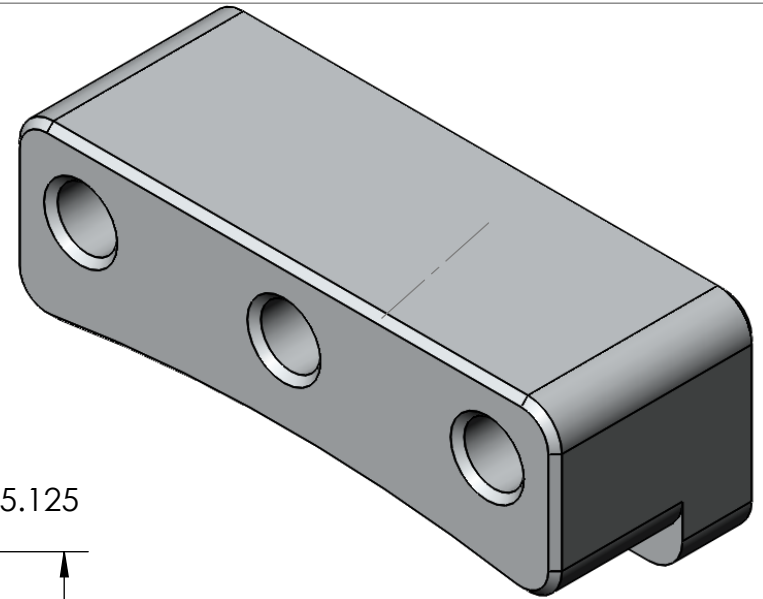
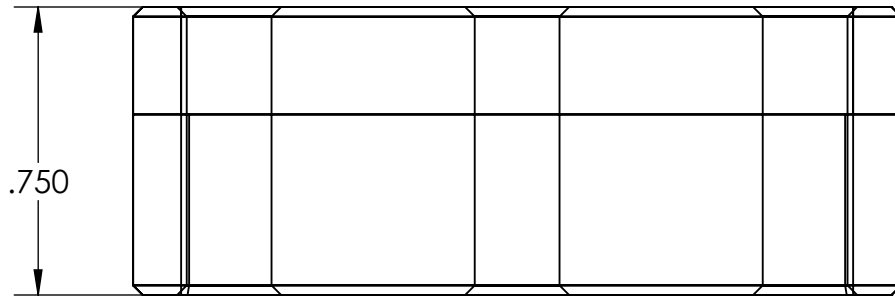

PROPRIETARY AND CONFIDENTIAL
 THE INFORMATION CONTAINED IN THIS DRAWING IS THE SOLE PROPERTY OF <INSERT COMPANY NAME HERE>. ANY REPRODUCTION IN PART OR AS A WHOLE WITHOUT THE WRITTEN PERMISSION OF <INSERT COMPANY NAME HERE> IS PROHIBITED.

		DIMENSIONS ARE IN INCHES		NAME	DATE	IAUNAM instrumentacion	
		TOLERANCES:		DRAWN	JV		
		FRACTIONAL ±		CHECKED			
		ANGULAR: MACH ± BEND ±		ENG APPR.		FILTER-WHEEL-CLAMP-RADI	
		TWO PLACE DECIMAL ±		MFG APPR.			
		THREE PLACE DECIMAL ±		Q.A.			
		MATERIAL		COMMENTS:			
		ALUMINUM 6061		MACHINED PER CAD FILE			
NEXT ASSY	USED ON	FINISH		SIZE		DWG. NO.	
		BLACK ANODIZE		A			
APPLICATION		DO NOT SCALE DRAWING		SCALE:2:1		WEIGHT:	
						SHEET 1 OF 1	

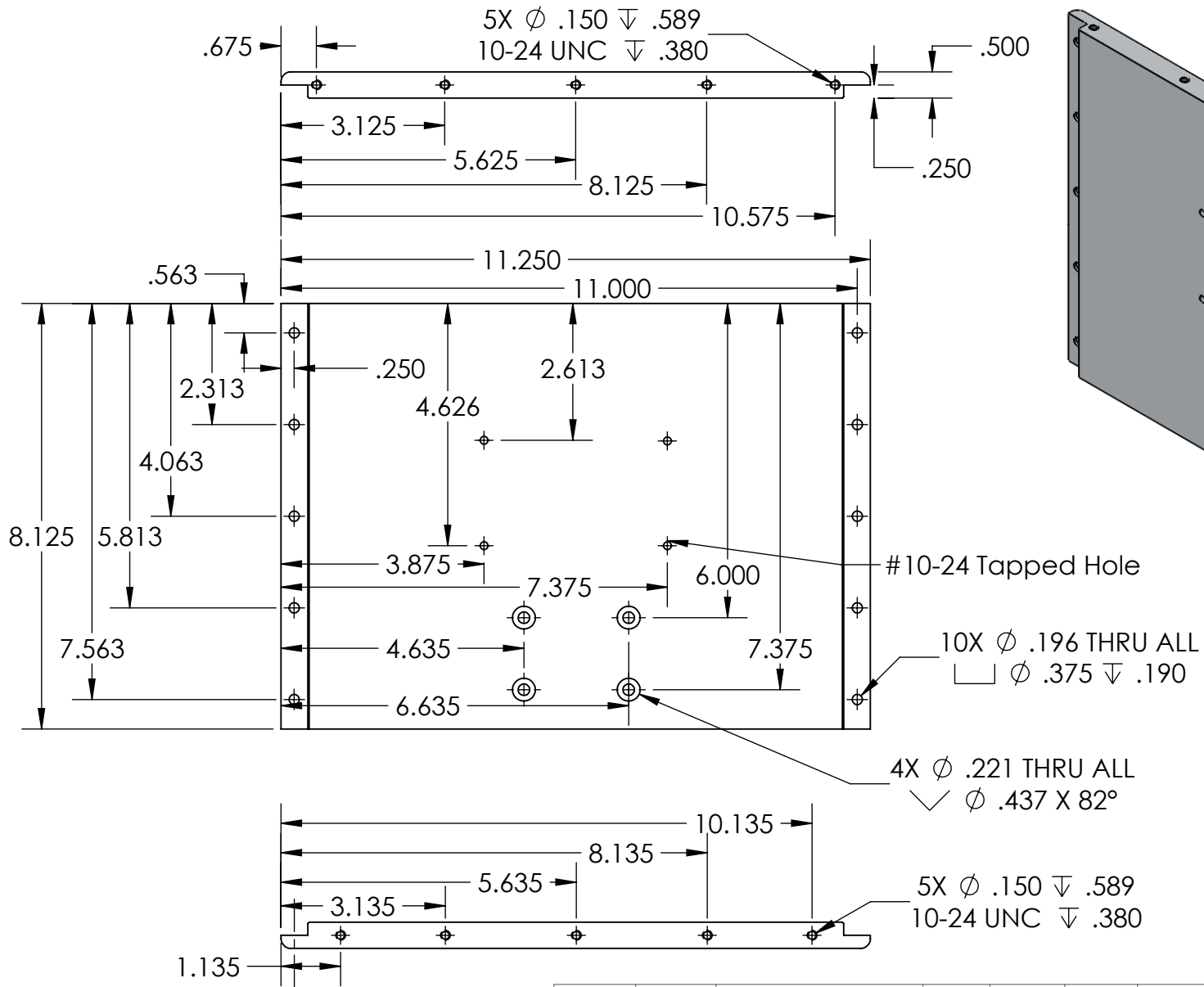

PROPRIETARY AND CONFIDENTIAL
THE INFORMATION CONTAINED IN THIS DRAWING IS THE SOLE PROPERTY OF <INSERT COMPANY NAME HERE>. ANY REPRODUCTION IN PART OR AS A WHOLE WITHOUT THE WRITTEN PERMISSION OF <INSERT COMPANY NAME HERE> IS PROHIBITED.

		DIMENSIONS ARE IN INCHES TOLERANCES: FRACTIONAL ± ANGULAR: MACH ± BEND ± TWO PLACE DECIMAL ± THREE PLACE DECIMAL ±		NAME J V	DATE	IAUNAM instrumentacion	
		MATERIAL ALUMINUM 6061		DRAWN		FRONT WALL	
		FINISH BLACK ANODIZE		CHECKED			
NEXT ASSY		USED ON		ENG APPR.			
APPLICATION		DO NOT SCALE DRAWING		MFG APPR.			
				Q.A.		MACHINED PER CAD FILE	
				COMMENTS:			
				SIZE A	DWG. NO.		
				SCALE:1:3		WEIGHT:	SHEET 1 OF 2

10X ϕ .196 THRU ALL
 \square ϕ .375 ∇ .190

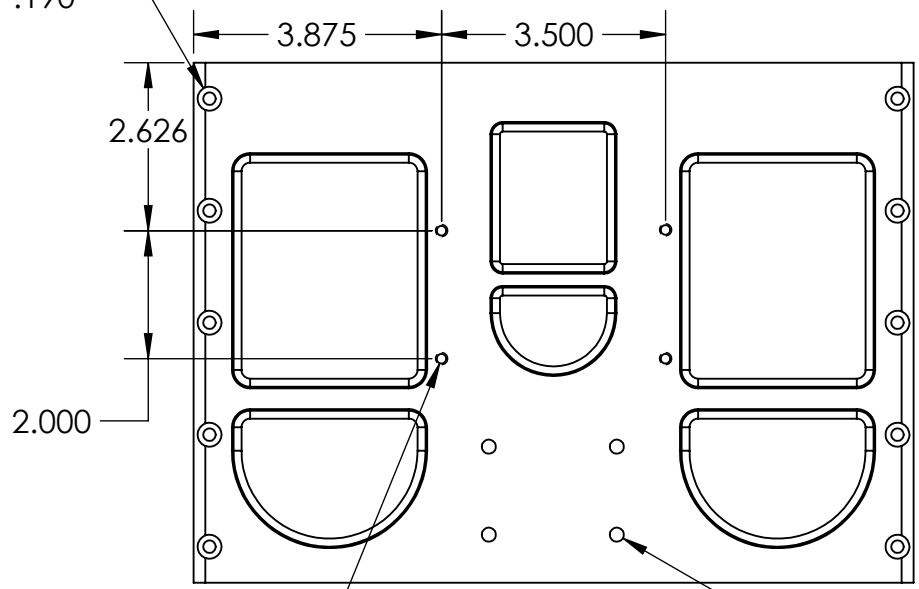

4X ϕ .150 ∇ .589
 10-24 UNC ∇ .380

4X ϕ .221 THRU ALL
 \surd ϕ .437 X 82°

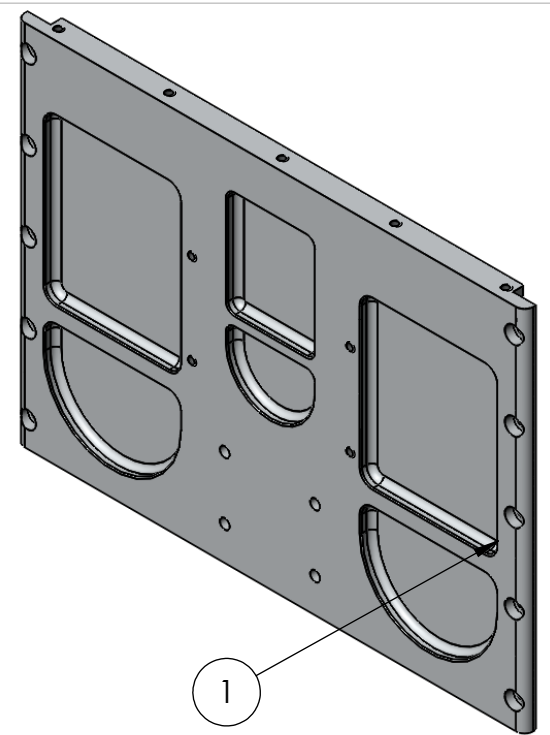

PROPRIETARY AND CONFIDENTIAL
 THE INFORMATION CONTAINED IN THIS DRAWING IS THE SOLE PROPERTY OF <INSERT COMPANY NAME HERE>. ANY REPRODUCTION IN PART OR AS A WHOLE WITHOUT THE WRITTEN PERMISSION OF <INSERT COMPANY NAME HERE> IS PROHIBITED.

		UNLESS OTHERWISE SPECIFIED:	NAME	DATE
		DIMENSIONS ARE IN INCHES	DRAWN	
		TOLERANCES:	CHECKED	
		FRACTIONAL \pm	ENG APPR.	
		ANGULAR: MACH \pm BEND \pm	MFG APPR.	
		TWO PLACE DECIMAL \pm	Q.A.	
		THREE PLACE DECIMAL \pm	COMMENTS:	
		INTERPRET GEOMETRIC TOLERANCING PER:	MACHINED PER CAD FILE	
		MATERIAL		
		ALUMINUM 6061		
		FINISH		
		BLACK ANODIZE		
NEXT ASSY	USED ON	DO NOT SCALE DRAWING		
APPLICATION				

TITLE:
FRONT-WALL

SIZE	DWG. NO.	REV
A		
SCALE: 1:3	WEIGHT:	SHEET 2 OF 2

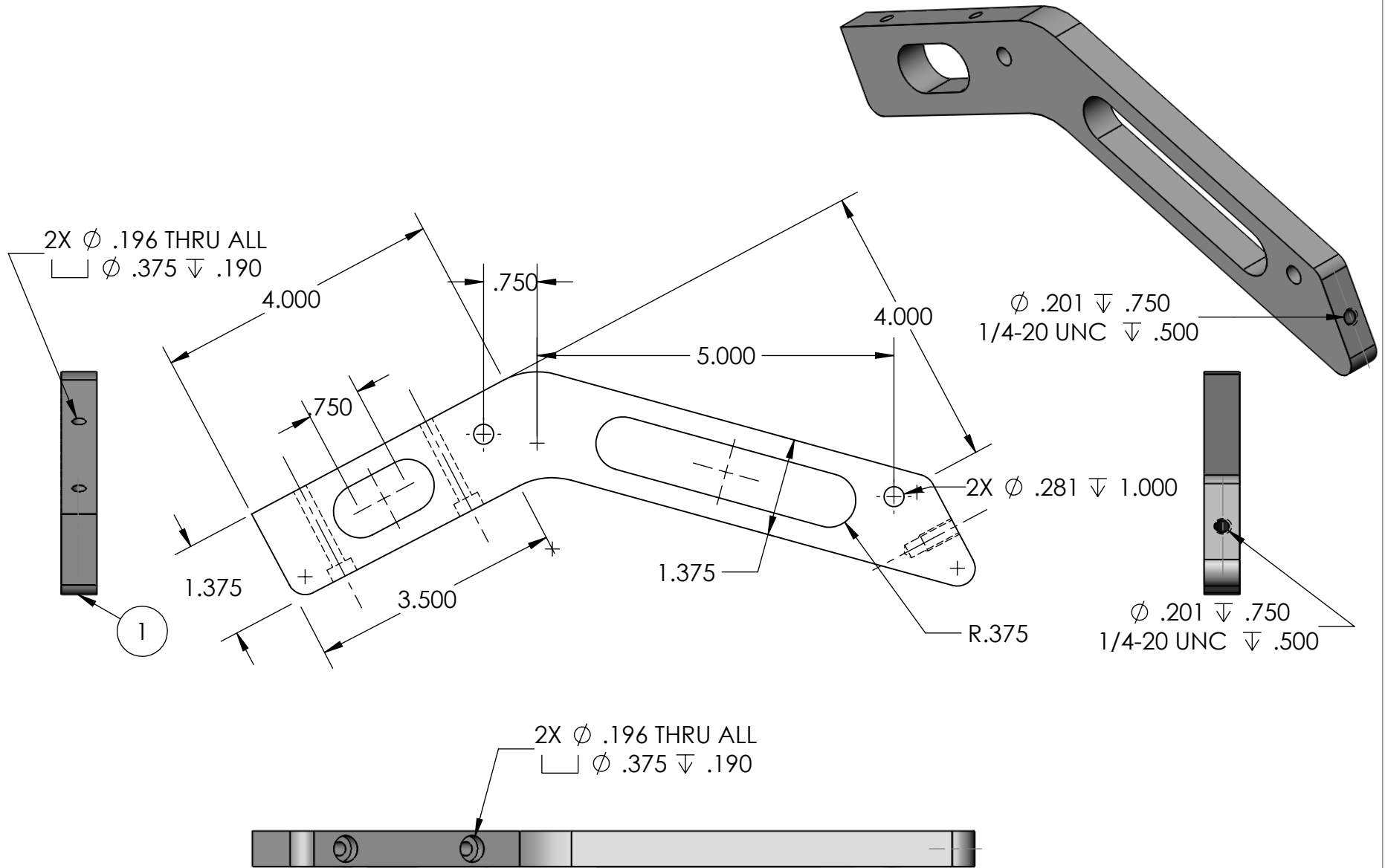

PROPRIETARY AND CONFIDENTIAL
 THE INFORMATION CONTAINED IN THIS DRAWING IS THE SOLE PROPERTY OF <INSERT COMPANY NAME HERE>. ANY REPRODUCTION IN PART OR AS A WHOLE WITHOUT THE WRITTEN PERMISSION OF <INSERT COMPANY NAME HERE> IS PROHIBITED.

		DIMENSIONS ARE IN INCHES TOLERANCES: FRACTIONAL ± ANGULAR: MACH ± BEND ± TWO PLACE DECIMAL ± THREE PLACE DECIMAL ±		NAME JV	DATE	IAUNAM instrumentacion	
		MATERIAL ALUMINUM 6061		CHECKED		HOSE-ARM-SUPPORT	
		FINISH BLACK ANODIZE		ENG APPR.			
NEXT ASSY	USED ON	COMMENTS: MACHINED PER CAD FILE		MFG APPR.		SIZE A	DWG. NO.
APPLICATION		DO NOT SCALE DRAWING		Q.A.		SCALE:1:2	WEIGHT:
						SHEET 1 OF 1	

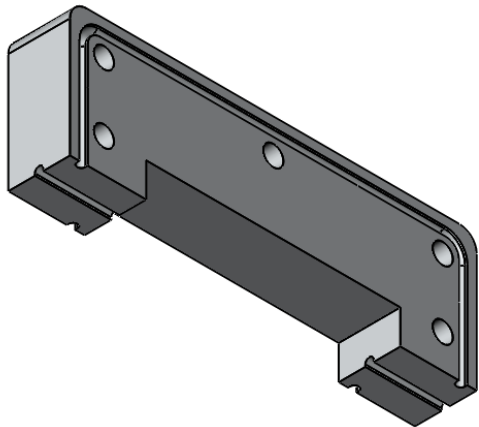
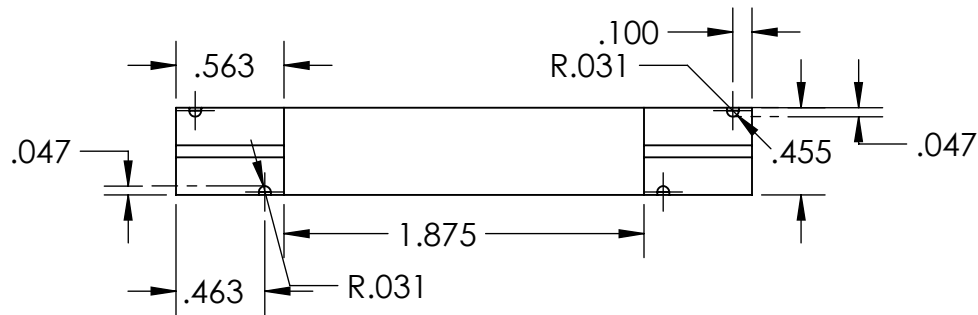
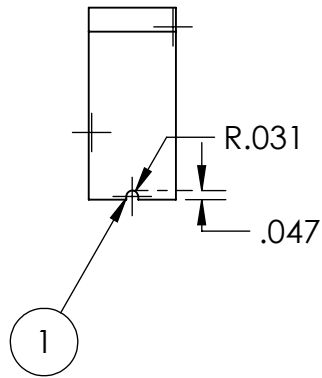
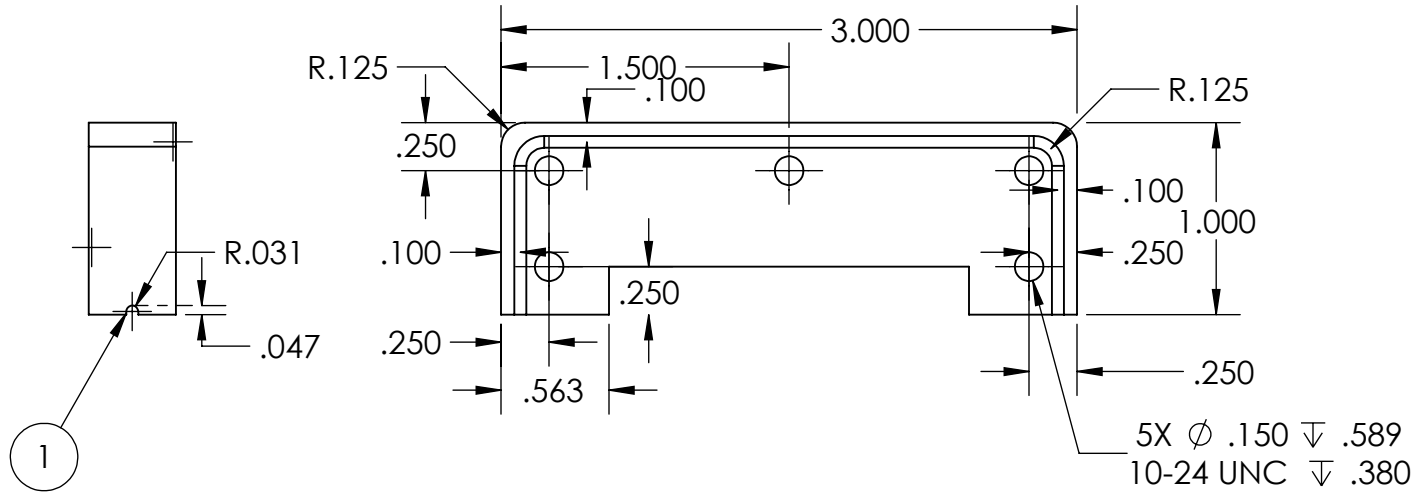
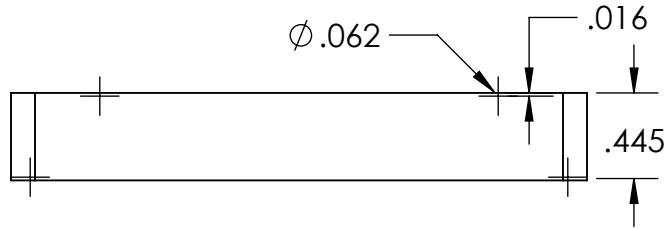
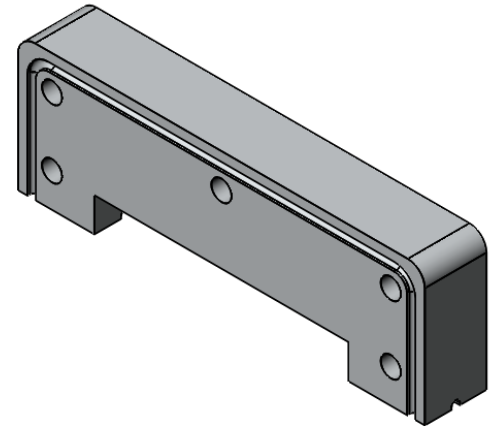

PROPRIETARY AND CONFIDENTIAL
 THE INFORMATION CONTAINED IN THIS DRAWING IS THE SOLE PROPERTY OF <INSERT COMPANY NAME HERE>. ANY REPRODUCTION IN PART OR AS A WHOLE WITHOUT THE WRITTEN PERMISSION OF <INSERT COMPANY NAME HERE> IS PROHIBITED.

		DIMENSIONS ARE IN INCHES TOLERANCES: FRACTIONAL ± ANGULAR: MACH ± BEND ± TWO PLACE DECIMAL ± THREE PLACE DECIMAL ±		NAME J V	DATE	IAUNAM instrumentacion		
		MATERIAL ALUMINUM 6061		CHECKED		LIGHT-TRAP		
		FINISH BLACK ANODIZE		ENG APPR.				
		COMMENTS: MACHINED PER CAD FILE		MFG APPR.				
Q.A.						SIZE A	DWG. NO.	REV.
SCALE:1:1		WEIGHT:		SHEET 1 OF 1				

NEXT ASSY	USED ON	APPLICATION	DO NOT SCALE DRAWING
-----------	---------	-------------	----------------------

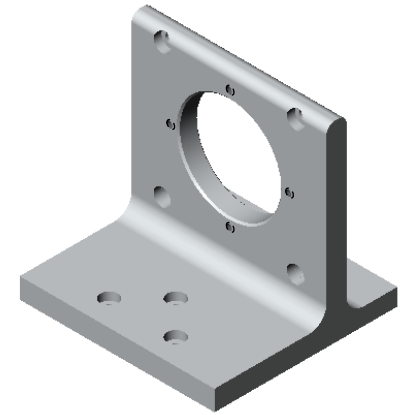

5X ϕ .126 THRU ALL
 $\lfloor \phi$.256 ∇ .118

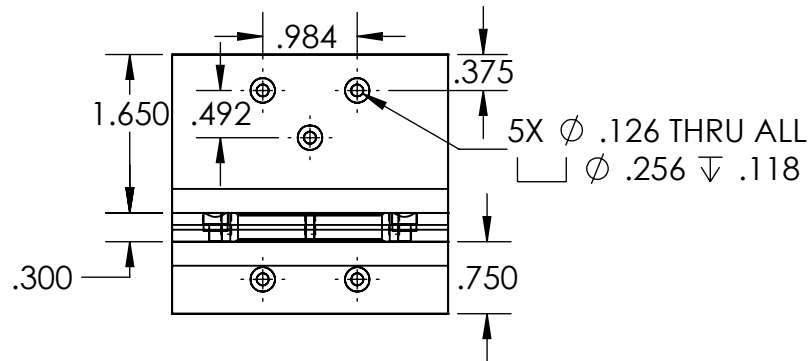
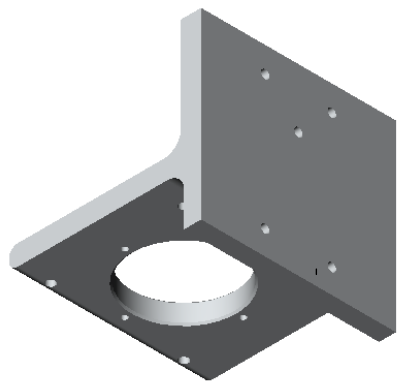
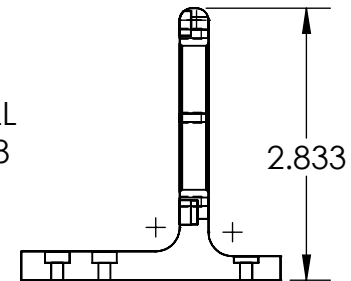
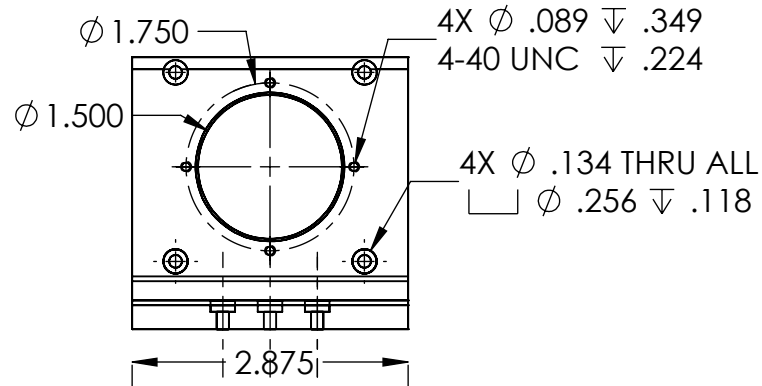
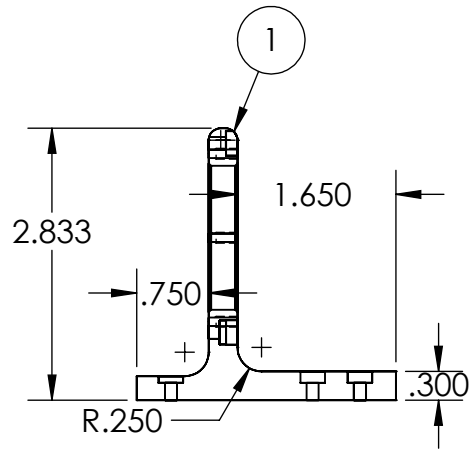
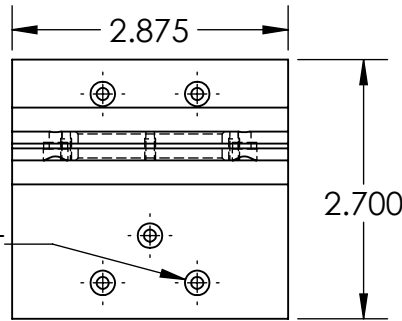

PROPRIETARY AND CONFIDENTIAL
 THE INFORMATION CONTAINED IN THIS DRAWING IS THE SOLE PROPERTY OF <INSERT COMPANY NAME HERE>. ANY REPRODUCTION IN PART OR AS A WHOLE WITHOUT THE WRITTEN PERMISSION OF <INSERT COMPANY NAME HERE> IS PROHIBITED.

		DIMENSIONS ARE IN INCHES TOLERANCES: FRACTIONAL \pm ANGULAR: MACH \pm BEND \pm TWO PLACE DECIMAL \pm THREE PLACE DECIMAL \pm		NAME J V	DATE	IAUNAM instrumentacion		
		MATERIAL ALUMINUM 6061		DRAWN		ROTA-GUZZET		
		FINISH BLACK ANODIZE		CHECKED				
NEXT ASSY		USED ON		ENG APPR.		MACHINED PER CAD FILE		
APPLICATION		DO NOT SCALE DRAWING		MFG APPR.				
				Q.A.		COMMENTS:		
						SIZE A	DWG. NO.	REV.
						SCALE:1:2	WEIGHT:	SHEET 1 OF 1

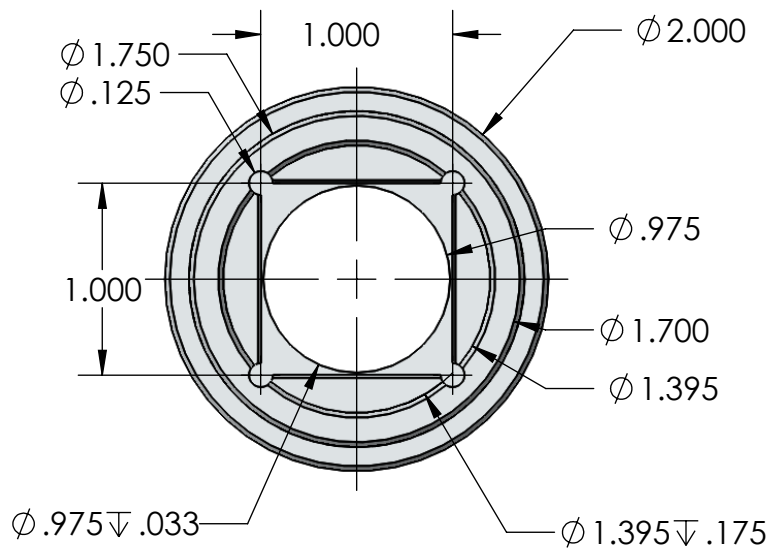
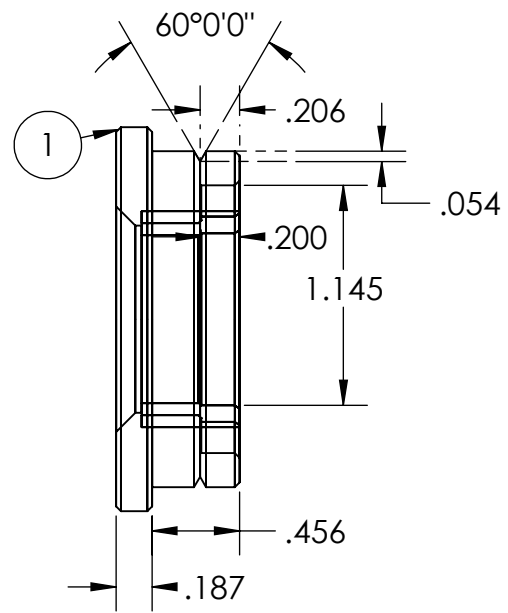
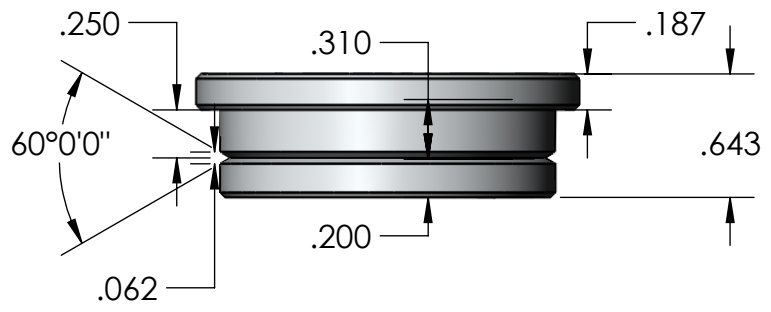

PROPRIETARY AND CONFIDENTIAL
 THE INFORMATION CONTAINED IN THIS DRAWING IS THE SOLE PROPERTY OF <INSERT COMPANY NAME HERE>. ANY REPRODUCTION IN PART OR AS A WHOLE WITHOUT THE WRITTEN PERMISSION OF <INSERT COMPANY NAME HERE> IS PROHIBITED.

		DIMENSIONS ARE IN INCHES TOLERANCES: FRACTIONAL ± ANGULAR: MACH ± BEND ± TWO PLACE DECIMAL ± THREE PLACE DECIMAL ±		NAME J V	DATE	IAUNAM instrumentacion		
		MATERIAL ALUMINUM 6061		CHECKED		SABA-CELL-ROTA		
		FINISH BLACK ANODIZE		ENG APPR.				
		APPLICATION DO NOT SCALE DRAWING		MFG APPR.				
NEXT ASSY	USED ON	COMMENTS: MACHINED PER CAD FILE		Q.A.		SIZE A	DWG. NO.	REV.
						SCALE:1:1	WEIGHT:	SHEET 1 OF 1

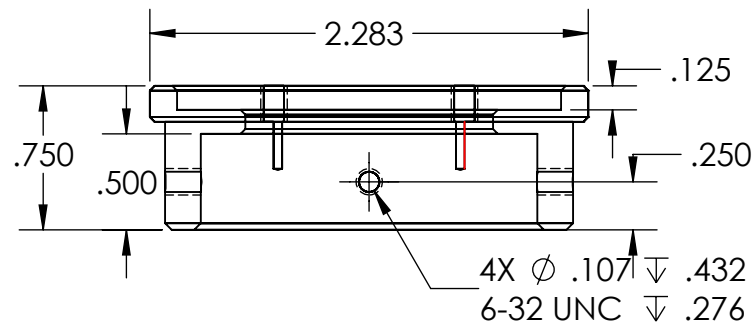
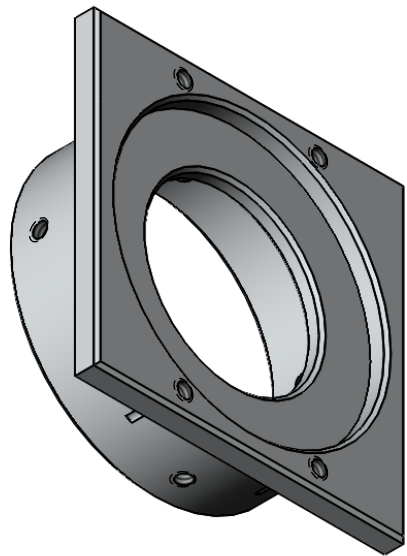
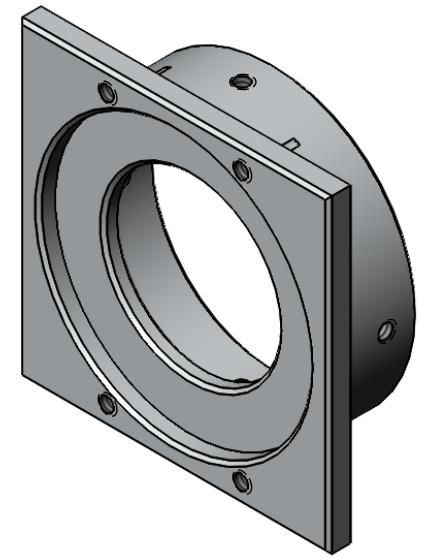
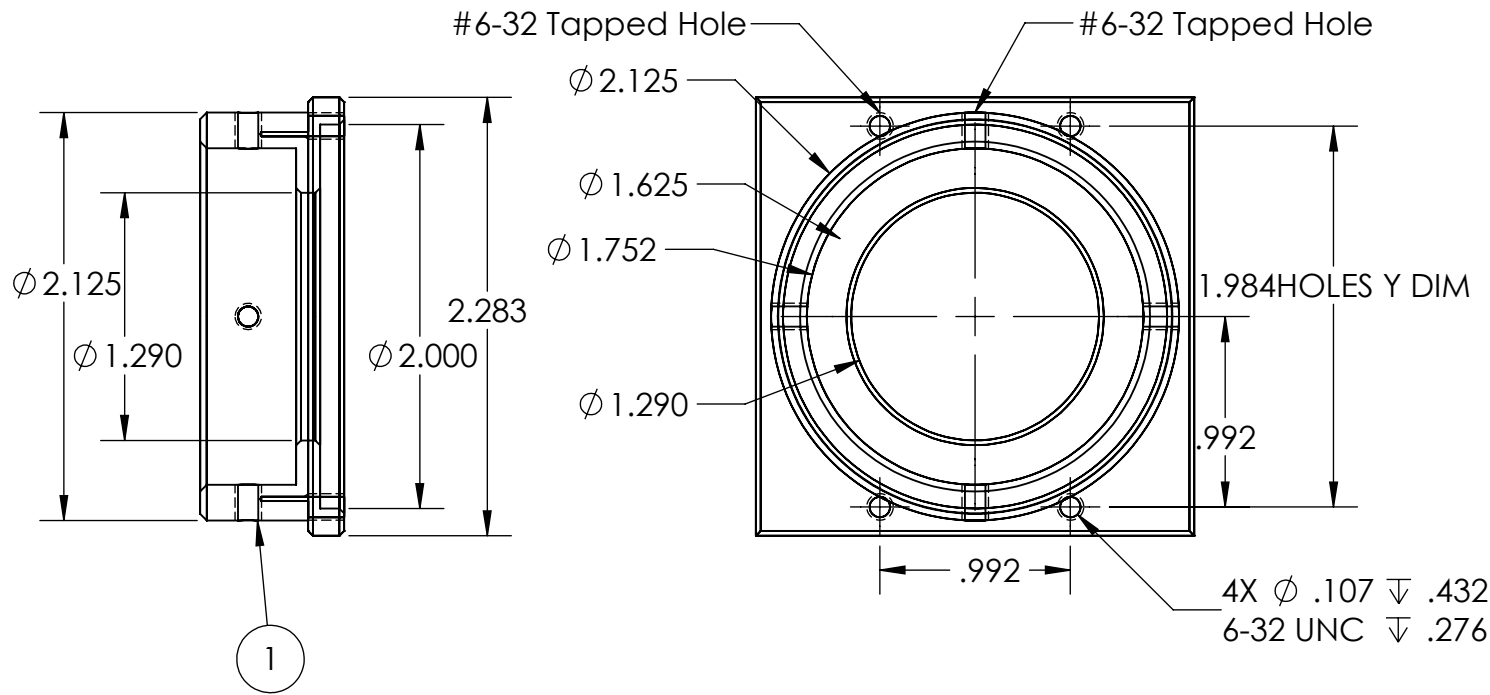

PROPRIETARY AND CONFIDENTIAL
THE INFORMATION CONTAINED IN THIS DRAWING IS THE SOLE PROPERTY OF <INSERT COMPANY NAME HERE>. ANY REPRODUCTION IN PART OR AS A WHOLE WITHOUT THE WRITTEN PERMISSION OF <INSERT COMPANY NAME HERE> IS PROHIBITED.

		DIMENSIONS ARE IN INCHES TOLERANCES: FRACTIONAL \pm ANGULAR: MACH \pm BEND \pm TWO PLACE DECIMAL \pm THREE PLACE DECIMAL \pm		NAME J V	DATE	IAUNAM instrumentacion	
		MATERIAL ALUMINUM 6061		CHECKED		SAVART-CELL	
		FINISH BLACK ANODIZE		ENG APPR.			
		APPLICATION DO NOT SCALE DRAWING		MFG APPR.			
NEXT ASSY	USED ON			Q.A.		COMMENTS: MACHINED PER CAD FILE	
				SIZE A	DWG. NO.	REV.	
				SCALE:1:1	WEIGHT:	SHEET 1 OF 1	

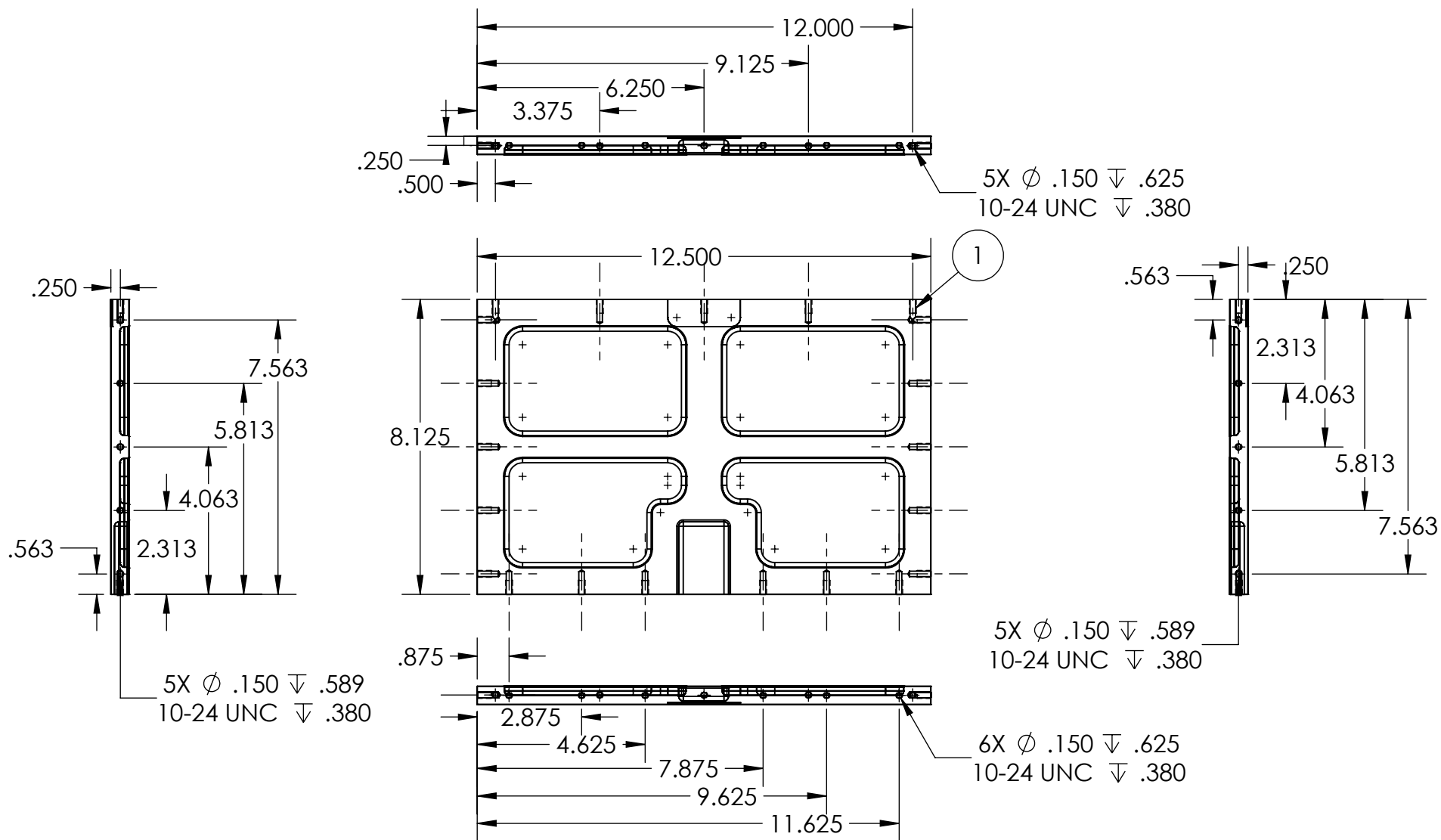

PROPRIETARY AND CONFIDENTIAL
 THE INFORMATION CONTAINED IN THIS DRAWING IS THE SOLE PROPERTY OF <INSERT COMPANY NAME HERE>. ANY REPRODUCTION IN PART OR AS A WHOLE WITHOUT THE WRITTEN PERMISSION OF <INSERT COMPANY NAME HERE> IS PROHIBITED.

		DIMENSIONS ARE IN INCHES TOLERANCES: FRACTIONAL ± ANGULAR: MACH ± BEND ± TWO PLACE DECIMAL ± THREE PLACE DECIMAL ±		NAME J V	DATE	IAUNAM instrumentacion	
		MATERIAL ALUMINUM 6061		CHECKED		SIDE-WALL-1	
		FINISH BLACK ANODIZE		ENG APPR.			
NEXT ASSY	USED ON			MFG APPR.			
APPLICATION		DO NOT SCALE DRAWING		Q.A.			
				COMMENTS: MACHINED PER CAD FILE			
				SIZE A	DWG. NO.		REV.
				SCALE:1:4	WEIGHT:		SHEET 1 OF 1

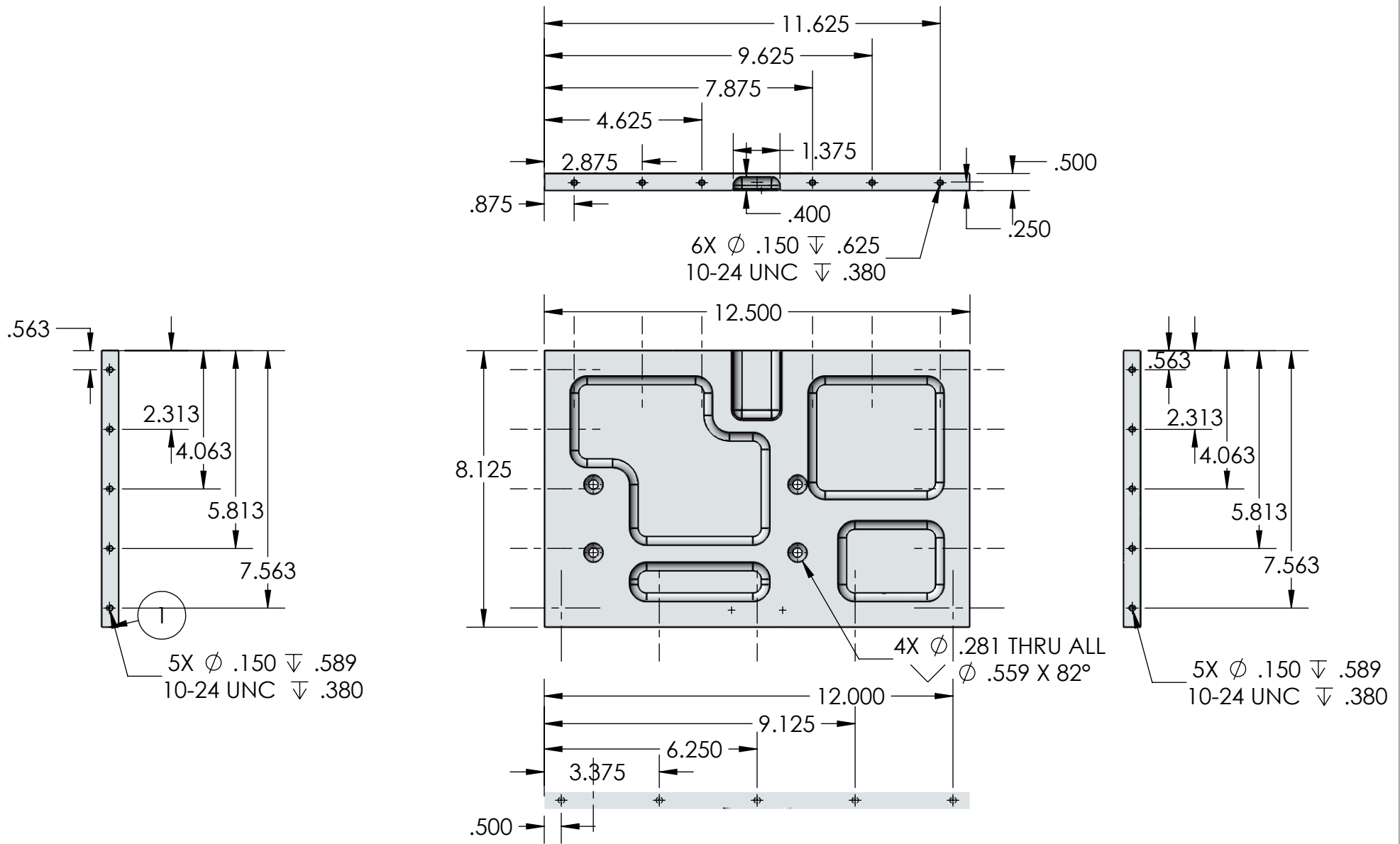

PROPRIETARY AND CONFIDENTIAL
 THE INFORMATION CONTAINED IN THIS DRAWING IS THE SOLE PROPERTY OF <INSERT COMPANY NAME HERE>. ANY REPRODUCTION IN PART OR AS A WHOLE WITHOUT THE WRITTEN PERMISSION OF <INSERT COMPANY NAME HERE> IS PROHIBITED.

		DIMENSIONS ARE IN INCHES TOLERANCES: FRACTIONAL ± ANGULAR: MACH ± BEND ± TWO PLACE DECIMAL ± THREE PLACE DECIMAL ±		NAME J V	DATE	IAUNAM instrumentacion	
		MATERIAL ALUMINUM 6061		CHECKED		SIDE-WALL-2	
		FINISH BLACK ANODIZE		ENG APPR.			
NEXT ASSY		USED ON		MFG APPR.		SIZE A DWG. NO. REV. SCALE:1:4 WEIGHT: SHEET 1 OF 1	
APPLICATION		DO NOT SCALE DRAWING		Q.A.			
				COMMENTS: MACHINED PER CAD FILE			

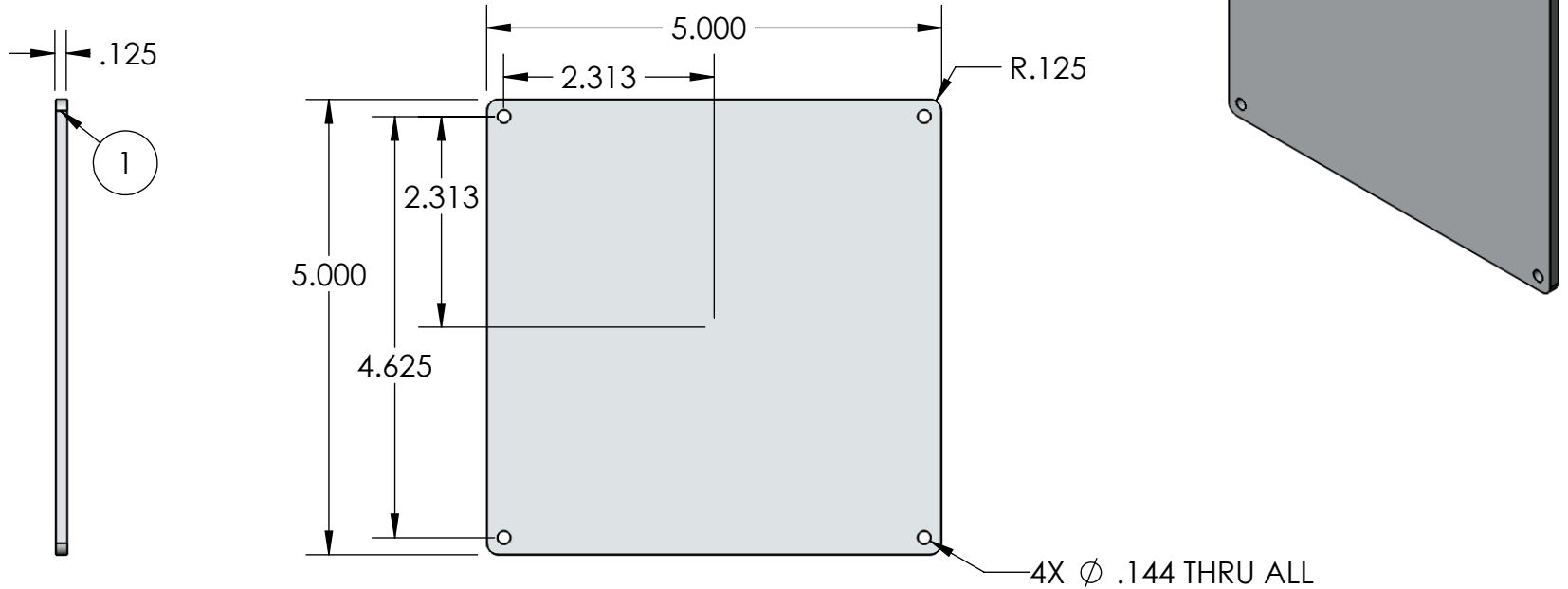

PROPRIETARY AND CONFIDENTIAL
 THE INFORMATION CONTAINED IN THIS DRAWING IS THE SOLE PROPERTY OF <INSERT COMPANY NAME HERE>. ANY REPRODUCTION IN PART OR AS A WHOLE WITHOUT THE WRITTEN PERMISSION OF <INSERT COMPANY NAME HERE> IS PROHIBITED.

		DIMENSIONS ARE IN INCHES		NAME	DATE	IAUNAM instrumentacion	
		TOLERANCES:		DRAWN	JV		
		FRACTIONAL ±		CHECKED			
		ANGULAR: MACH ± BEND ±		ENG APPR.			
		TWO PLACE DECIMAL ±		MFG APPR.			
		THREE PLACE DECIMAL ±		Q.A.			
		MATERIAL		COMMENTS:		SPECS-PLATE	
		ALUMINUM SHEET		MACHINED PER CAD FILE			
NEXT ASSY	USED ON	FINISH ANODIZE BLACK		SIZE	DWG. NO.	REV.	
APPLICATION		DO NOT SCALE DRAWING		A			
				SCALE:1:2	WEIGHT:	SHEET 1 OF 1	

(1) - 20 THREADS PER INCH 2B .043 MIN DEPTH

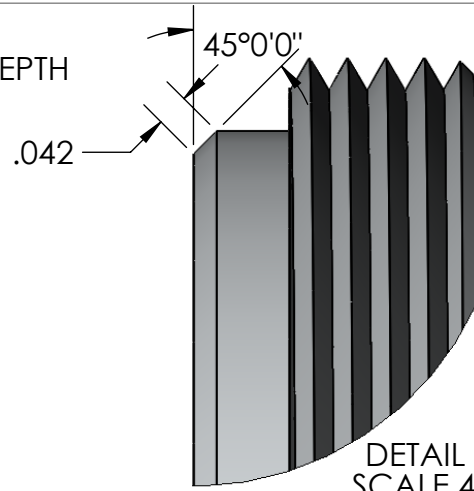

DETAIL A
SCALE 4:1

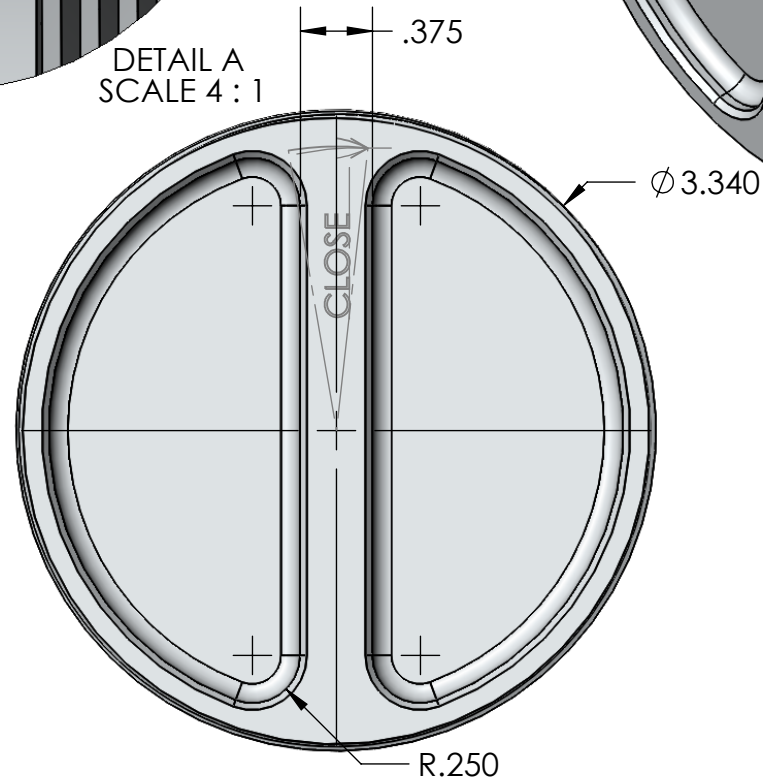
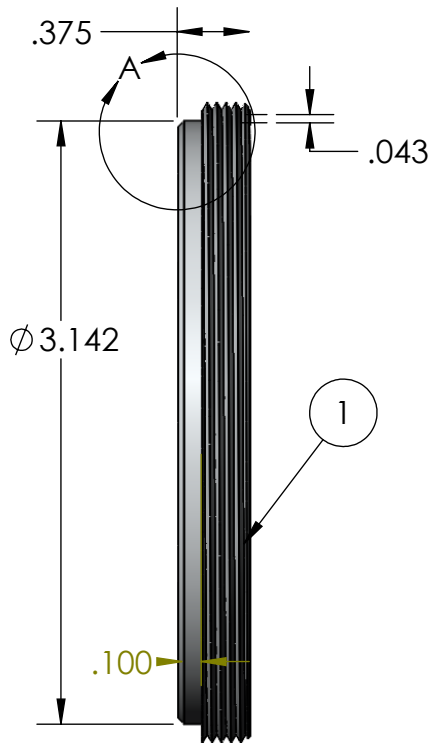
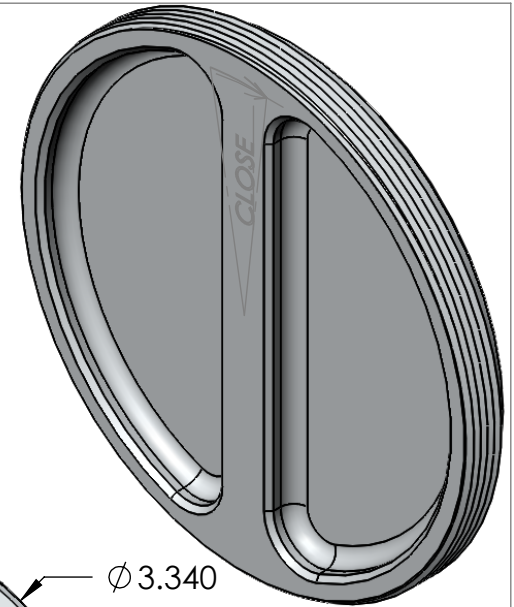

PROPRIETARY AND CONFIDENTIAL
 THE INFORMATION CONTAINED IN THIS DRAWING IS THE SOLE PROPERTY OF <INSERT COMPANY NAME HERE>. ANY REPRODUCTION IN PART OR AS A WHOLE WITHOUT THE WRITTEN PERMISSION OF <INSERT COMPANY NAME HERE> IS PROHIBITED.

		DIMENSIONS ARE IN INCHES		NAME	DATE	IAUNAM instrumentacion		
		TOLERANCES:		DRAWN	JV			
		FRACTIONAL ±		CHECKED				
		ANGULAR: MACH ± BEND ±		ENG APPR.				
		TWO PLACE DECIMAL ±		MFG APPR.				
		THREE PLACE DECIMAL ±		Q.A.				
		MATERIAL ALUMINUM		COMMENTS:		TOP DUST COVER		
		FINISH RED ANODIZED		MACHINED PER CAD FILE				
NEXT ASSY	USED ON	APPLICATION		DO NOT SCALE DRAWING		SIZE A	DWG. NO.	REV.
						SCALE:1:1	WEIGHT:	SHEET 1 OF 1

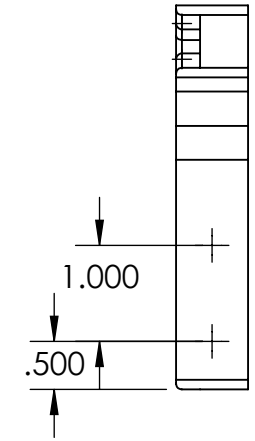
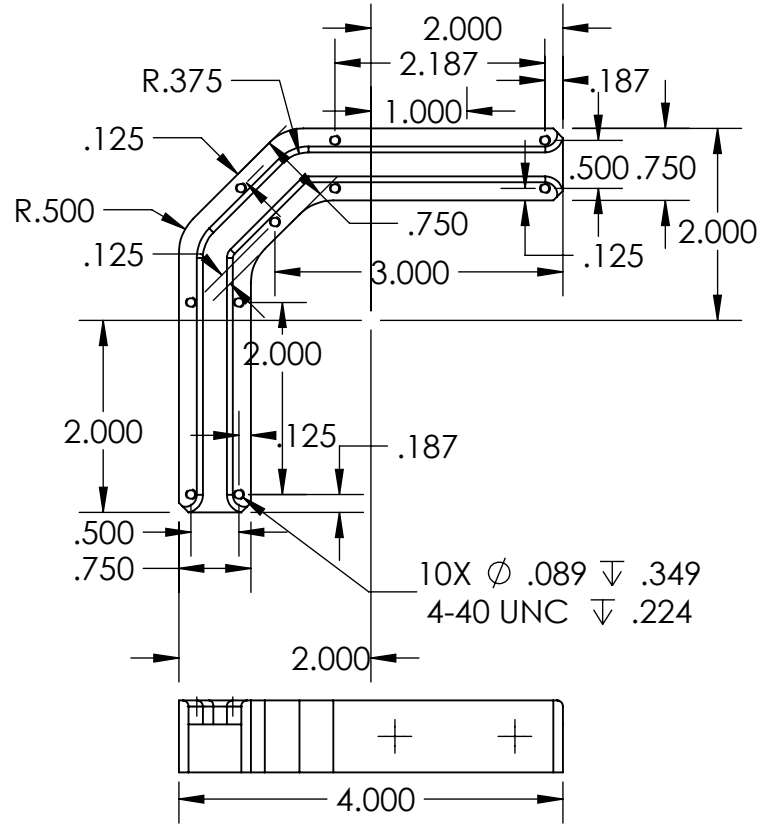
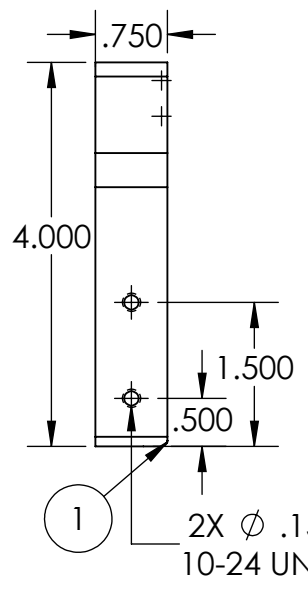
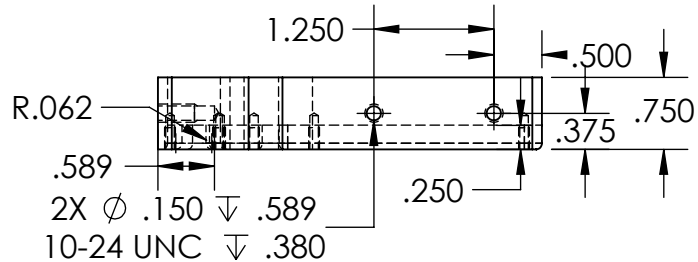
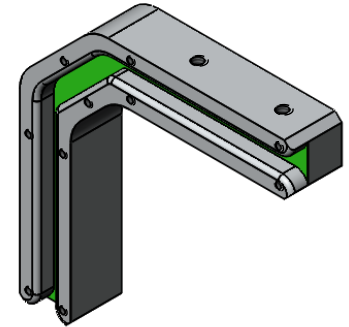

PROPRIETARY AND CONFIDENTIAL
 THE INFORMATION CONTAINED IN THIS DRAWING IS THE SOLE PROPERTY OF <INSERT COMPANY NAME HERE>. ANY REPRODUCTION IN PART OR AS A WHOLE WITHOUT THE WRITTEN PERMISSION OF <INSERT COMPANY NAME HERE> IS PROHIBITED.

		DIMENSIONS ARE IN INCHES TOLERANCES: FRACTIONAL ± ANGULAR: MACH ± BEND ± TWO PLACE DECIMAL ± THREE PLACE DECIMAL ±		NAME JV	DATE	IAUNAM instrumentacion		
		MATERIAL ALUMINUM 6061		CHECKED		WALL SUPPORT		
		FINISH BLACK ANODIZE		ENG APPR.				
		COMMENTS: MACHINED PER CAD FILE		MFG APPR.				
NEXT ASSY	USED ON			Q.A.		SIZE A	DWG. NO.	REV.
APPLICATION		DO NOT SCALE DRAWING				SCALE:1:2	WEIGHT:	SHEET 1 OF 1